

Operating instructions
(translation of the original Version in German)



Wetrok

Monovac Comfort 6/11
Monovac Touch'n'Clean 6/11
Durovac 6/11

wetrok[®]

Dear Customer

Thank you for choosing a high-quality Wetrok product. In doing so, you have purchased a quality machine that will give you professional results for many years with the right care and correct use. We wish you a lot of enjoyment using your new Wetrok!

The Wetrok product management.

General



- Carefully read these operating instructions before commissioning. Always keep it within easy reach!
- These operating instructions provide all information necessary for operation, maintenance and care. It is integrated part of the machine and must be passed on to an eventual new owner.
- Wetrok also supplies it's customers with this booklet on the internet under techinfo.wetrok.com.

Introduction

All instructions in this operating manual are intended for all types of Monovac/Durovac machines. Specific information in this operating manual is marked accordingly.

Table of Contents

Dear Customer.....	1	Maintenance / Repair.....	16
General.....	1	Troubleshooting	21
Symbols.....	3	Storage, disposal	23
Intended Use.....	4	Technical Data Monovac	23
Safety.....	5	Technical Data Durovac	25
Emergency.....	6	Copyright	25
Guarantee provisions	6	UKCA Declaration of Conformity	26
Scope of delivery	6		
Machine overview front view Monovac.....	7		
Machine overview backside Monovac.....	8		
Machine overview front view Durovac	9		
Machine overview backside Durovac	10		
Standard accessories / consumables	11		
Before commissioning / Initial commissioning	12		
Operation.....	12		

Symbols



DANGER

For an immediate threat that could lead to severe bodily injury or death.



WARNING

For a possible threat that could lead to severe bodily injury or death.



ATTENTION

For a possibly dangerous situation that can lead to damages.



NOTICE

For use or operation instructions and other useful information, but it is not for dangerous or harmful situations.



Mains supply



Protection class II



In compliance with the European directives for safety and EMC.



No household refuse. Dispose of in accordance with applicable laws and regulations.



Comply with the recycling regulations!



Explosion hazard

Intended Use

- This machine is designed for professional use, f.ex. usage in hotels, hospitals, factories, shops, offices and for rental business.
- Observance of all information in these operating instructions also pertain to the intended use.
- Any use of the machine, not mentioned under "intended use" is not allowed.
- Any kind of claims arising from damage resulting from improper use are excluded.



DANGER

- Vacuuming any types of dust that may be dangerous to health is prohibited.
- Vacuuming any type of liquid is prohibited.
- Vacuuming inflammable or explosive substances of any kind is prohibited.

This machine is electrically tested and satisfies European Safety Standards. It is constructed according to the available scientific information and state-of-the-art technology.

It is fitted with a safety device in the form of a circuit breaker. Dangers can occur in spite of this, in particular in the case of improper use or non-compliance with the specifications and instructions in these operating instructions.



WARNING

Electric voltage / electric current
Contact with voltage or current bearing parts carries the risk of electric shock, which can result in serious injury or even death.

- Never touch damaged cables. Have a skilled person replace faulty cables immediately.
- Always switch off and disconnect the power supply before carrying out any work on the machine.
- This machine is not intended for use by persons, including children, with reduced physical, sensory capabilities or lack of experience and knowledge.
- Children must be supervised to ensure that they do not play with the machine.
- The cleaning and maintenance may only be performed by trained and instructed personnel.
- Conversions and modifications to the machine are not permitted.
- Safety instructions for the use and the maintenance of the machine are listed in the corresponding chapters and must be strictly observed!
- Never use a defective machine.
- In case of use of a third party component (f.ex. charger), observe the prescriptions and indications in these instructions for use as well as those in the instructions for use of the third party.

Responsibility of the operator:

The machine is designed for professional use. The operator of the machine is therefore subject to the statutory obligations for occupational health and safety.

Besides the safety notices in these operating instructions, additionally, the national, and generally valid operation safety and accident prevention are binding.

In this the following applies in particular:

- The machine is only used by personnel instructed in its handling and authorized to use it.
- The operator must ensure that the recognized occupational safety regulations and all other legal or company internal provisions are observed.
- The operator must ensure that all users are acquainted with the safety regulations and trained in the use of the specific machine.
- The operator must ensure that responsibilities for the operation, maintenance and repair of the machine are clearly assigned and observed.
- The operator must ensure that all users have read and understood the operating instructions before using the machine.

Furthermore the operator must ensure that the machine is in perfect technical condition. Therefore following applies:

- It is the responsibility of the operator to ensure that the maintenance intervals described in these operating instructions are observed.
- The operator must ensure that all safety devices are controlled on function and completeness on a regular bases.
- Faults and damage must be immediately notified to the Wetrok Service Agent.

Responsibility of the user:

- The machine may only be used by personnel who have been instructed in its handling and authorized to use it.

Emergency

In the case of an emergency:

- Switch off machine
- Unplug mains plug
- Immediately apply recognised first-aid measures



After incidents, do not resume operation with the machine until it has been inspected by Wetrok.

Guarantee provisions

- Complaints will only be acknowledged if the machine has been repaired each time by Wetrok or a Wetrok authorized partner.
- The warranty period is generally 2 years (except for batteries and consumables).

Scope of delivery

Vacuum cleaner, inlet filter, fleece filter bag, suction hose, combination nozzle, exhaust filter, roll nozzle, telescopic tube, crevice nozzle, upholstery nozzle, Touch 'n' Clean handle*.

*Only Touch'n'Clean version

Vacuum cleaner, inlet filter, fleece filter bag, suction hose, combination nozzle, roll nozzle, hand pipe (2 pieces).

Machine overview front view

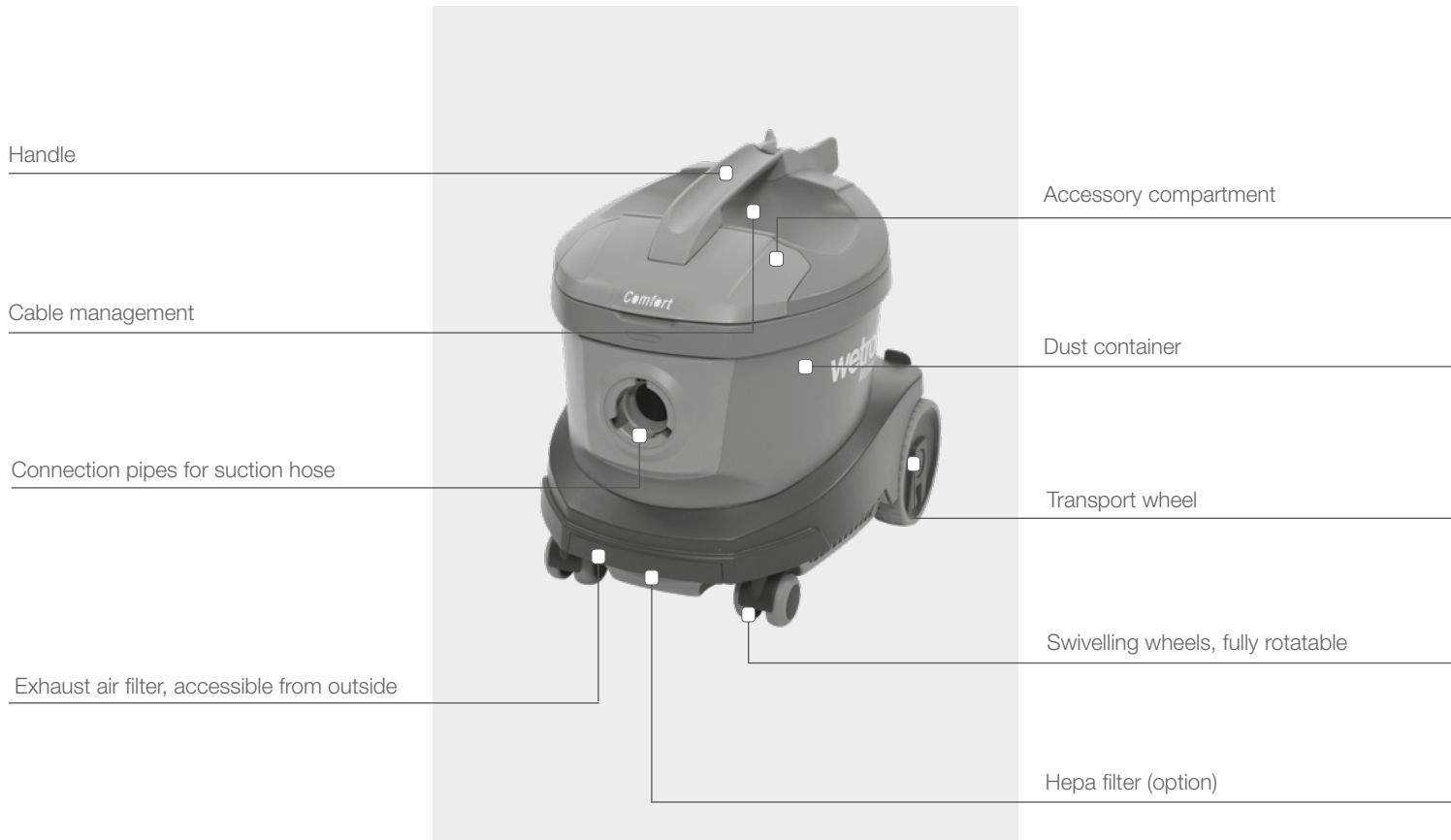

Machine overview backside

Cover release knob

Transport bracket suction pipe

Circuit breaker full/reduced

Holder accessory nozzles

Nameplate

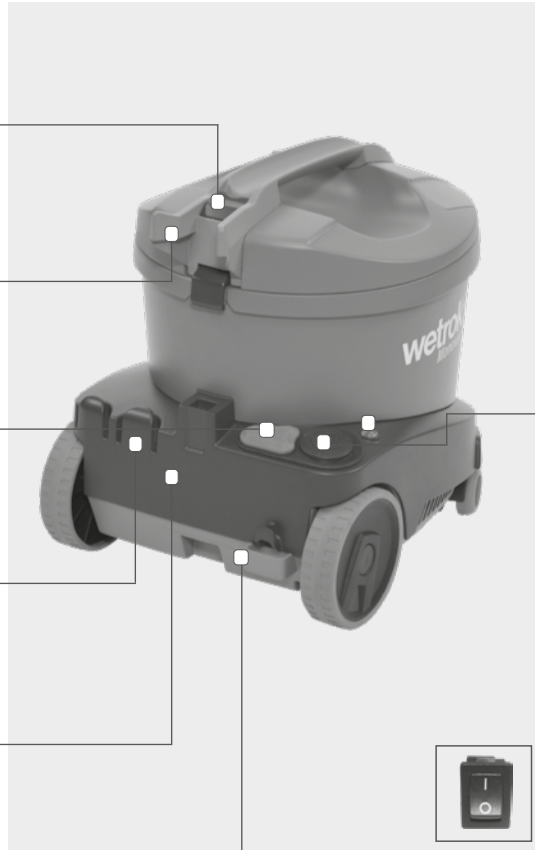

Filter bag filling indicator



Red LED lights up: change filter bag
Green LED lights up: Eco-mode ON

Foot switch ON/OFF

Strain relief power cord



12 m



220 - 240 V
50/60 Hz

Mains switch Touch'n'Clean

Machine overview front view

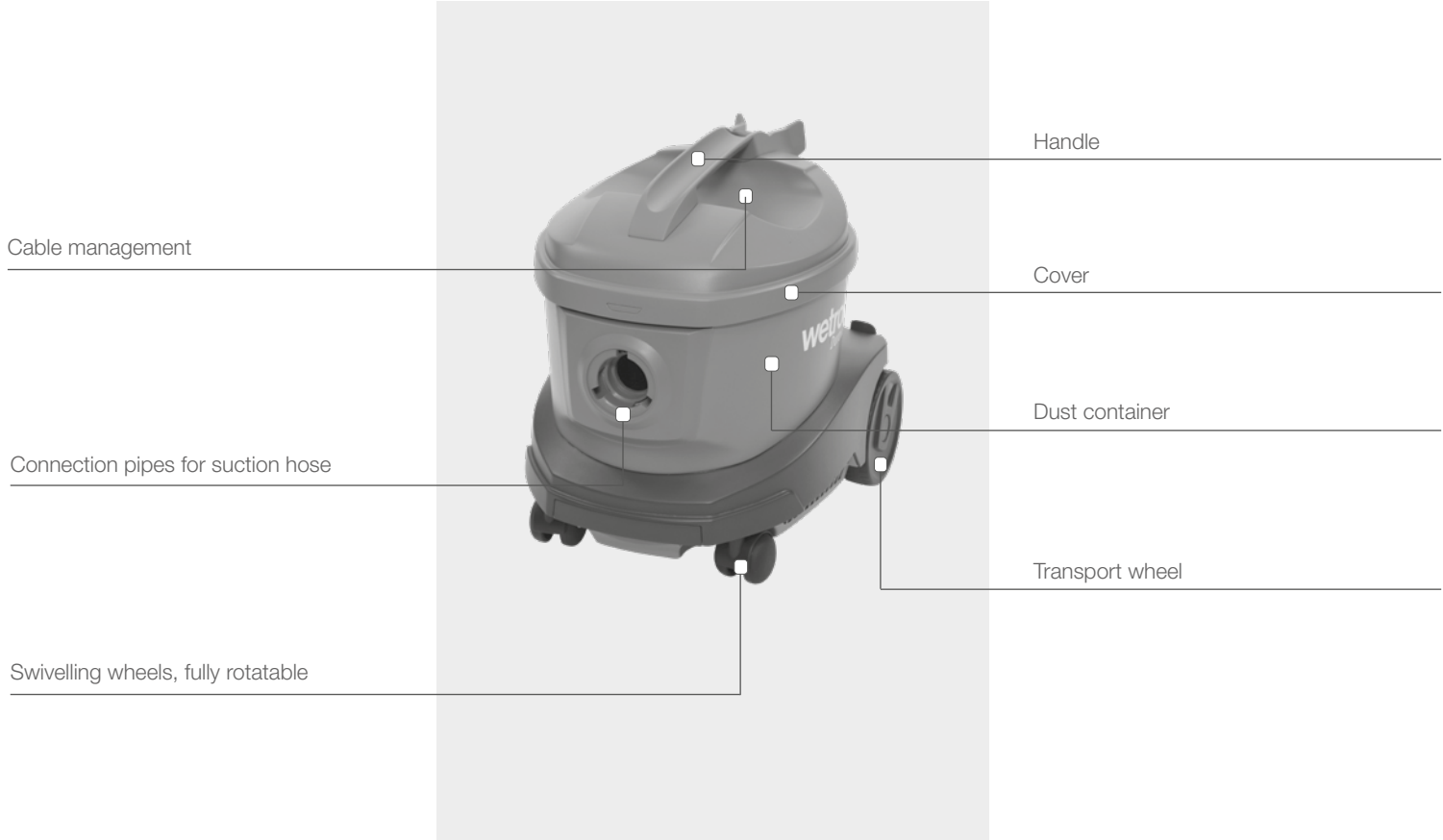

Cable management

Connection pipes for suction hose

Swivelling wheels, fully rotatable

Handle

Cover

Dust container

Transport wheel

Machine overview backside

Cover release knob

Transport bracket suction pipe

Holder accessory nozzles

Nameplate



Foot switch ON/OFF

Strain relief power cord

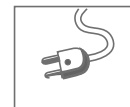

10 m



220 - 240 V
50/60 Hz

Standard accessories / consumables

Monovac / Durovac:



Suction hose



Roll nozzle



Fleece filter bag



Hand pipe



Combination nozzle

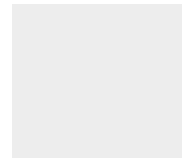

Monovac:
Telescopic tube



Monovac:
Crevice nozzle



Monovac:
Upholstery nozzle



Monovac:
Touch'n'Clean handle



More accessories on:
www.wetrok.com

Before commissioning / Initial commissioning

SICHERHEIT / SÉCURITÉ / SICUREZZA / SAFETY

Delivery, instruction on safety rules, handling and maintenance, as well as operation for the first time are normally carried out by a specialist approved by Wetrok. Where this is not the case, the operator is responsible for instructing the users.

All safety instructions must be complied with without fail!



WARNING

The machine must be fitted with a corresponding circuit breaker or a fuse link.



WARNING

The machine shall only be put into operation if the voltage stated on the nameplate (voltage $\pm 5\%$) agrees with the voltage available in the building. The machine has double insulation and no earth (ground) conductor.



NOTICE

Charge the T'n'C handle if necessary.
See page 30.

Operation

SAFETY

- The prescriptions and indications in these instructions for use need to be observed without exception.
- During operation, caution must be exercised with respect to third parties, especially children.
- Wear robust shoes or boots.
- Before cleaning and servicing the machine or exchanging parts, always pull out the mains connector plug.
- Use only original Wetrok working elements
- Do NOT use the machine if the condition of the mains connection cable is not flawless.



WARNING

Do not damage the mains connection cable by running over, squeezing, tugging or the like. Danger of an electric shock!



CAUTION

Do not leave the cable lying around. Tripping hazard!

- Only operate the machine in a technically perfect condition.
- Safety devices may not be removed or bypassed.
- Conversions and modifications to the product are not permitted
- Defective supply cables are only to be replaced flexible sheathed cables H 05 VV-F.

Operation



Connect suction hose with gland



Open/remove cover

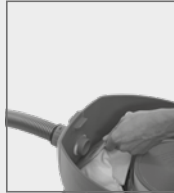

Put the filter bag in place¹

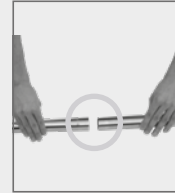

Assemble suction tube



Plug on suction nozzle



Unwind the cable

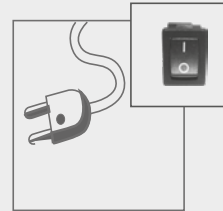

Insert power plug *

* Activate Touch'n'Clean mains switch

¹ See page 27 «Replacing the filter bag»

Operation

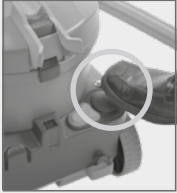

Press foot switch

or

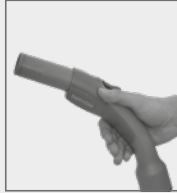

Touch handle
(Touch'n'Clean)



Monovac: Press circuit
breaker when required



NOTICE

- Never touch grip sensor with wet hands. The machine might not switch off when the handle is released.
- The handle navigates the machine via radio signal.

After use



or



Switch off the machine by pressing the foot switch

Switch off the machine by releasing the handle (Touch'n'Clean)

Disconnect the plug and rewind cable

Wipe off the machine with a clean, slightly damp cloth



NOTICE

Always keep the machine indoors in a dry, clean room.

Maintenance/ Repair



SICHERHEIT / SÉCURITÉ / SICUREZZA / SAFETY



WARNING

- Die Anweisungen und Vorschriften aus dieser Bedienungsanleitung sind ausnahmslos zu beachten.
- Before starting maintenance work or cleaning, switch off the machine and pull out the mains connector plug.
- Do not clean the machine with high pressure or steam or strong liquid jet.
- Use only original Wetrok spare parts for repairs.
- Examine mains connection cable for signs of damage or aging.
- The suction motor is maintenance-free.

Maintenance/ Repair

Monovac* / Durovac:

Wetrok machines are tested in the works for safety. For reliable operation and maintenance of value, regular servicing must be performed. Servicing shall only be performed by the Wetrok Service Department or authorised specialists.

Emptying dust:

- Replace the filter bag as soon as it is full.
 - * Replace the filter bag at the latest when the filling indicator lights.



WARNING

Operation without a filter bag inserted can lead to damage to the machine and will be at your own risk!

Maintenance/ Repair



Open/remove cover

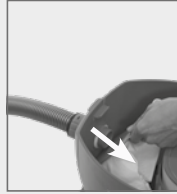

Tilt to the back



Lift cover plate, close filter bag, remove

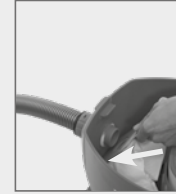

Insert filter bag into flute



Snap into place

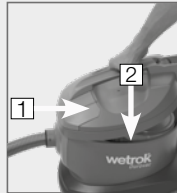

1. Put on the cover
2. Close the machine



NOTICE

- Dispose of the filter bag according to the regulations!

Maintenance / Repair

Inlet filter



VORSICHT / ATTENTION / ATTENZIONE / ATTENTION

Operation without an inlet filter inserted can lead to damage at the machine and will be at your own risk!

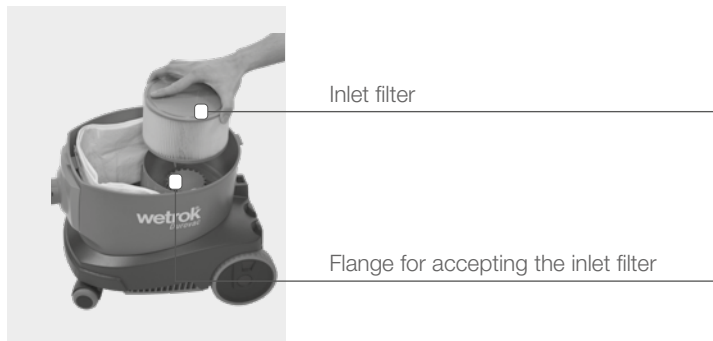

Checking and replacing the inlet filter:

- Check daily
- The inlet filter is attached to a flange and may be removed without tools. Check the inlet filter, vacuum with another vacuum cleaner or replace with a new one. Place the inlet filter on the flange and fix with moderate force. The inlet filter must always be securely attached during operation.

Exhaust filter Monovac

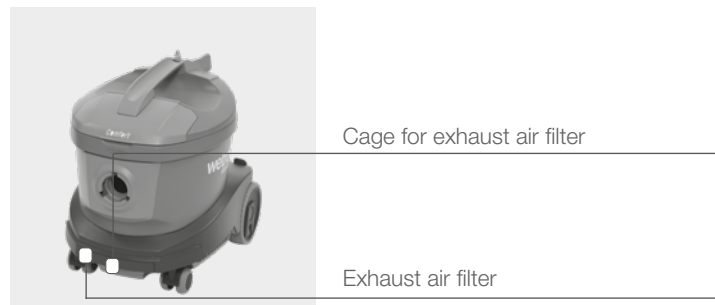

Checking and replacing the exhaust filter:

- Check daily
- Pull out exhaust air filter cage. Check exhaust air filter and replace if necessary. Insert exhaust air filter again.

Scope of delivery Touch'n'Clean handle

- The T'n'C handle is delivered with a Li-Po battery and charging cable.
- A charger for the T'n'C handle is NOT part of the scope of delivery.

Safety instructions Touch'n'Clean handle

- Danger of fire and/or explosion when Li-Po batteries are not handled correctly!
- Never cause a short-circuit.
- Refrain from mechanical treatment or load and never open the individual battery-cells.
- Never put the battery under high pressure nor temperatures above 60 °C.
- Observe all instructions in the instructions for use of the charger manufacturer.

Charging the Touch'n'Clean handle

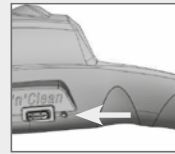

Connect the USB-C plug*

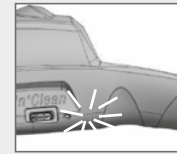

LED lights green

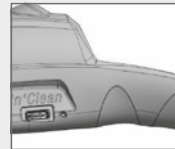

LED extinguished: done



- * Charger not part of the scope of delivery.

LED display

no display	Battery charge is sufficient
LED flashes orange	Lows battery charge
LED flashes orange, lights when touching the handle	Battery of the T'n'C handle is empty

Replace Touch'n'Clean handle

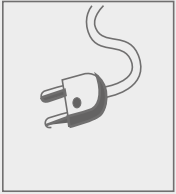

Remove the mains plug

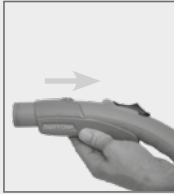

Mount the handle

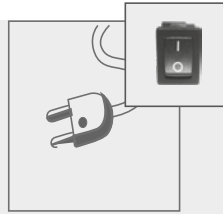

Plug in
Mains disconnector to "1"



Activate paring button with
a pen or paper clip

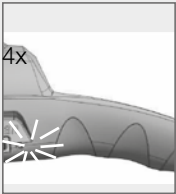

LED flashes orange



Vacuum cleaner switches on.
Stops after > 3 sec. → Done

HINWEIS / REMARQUE / AVISO / NOTICE



- The handle is coupled with the vacuum cleaner at delivery.
- Charge the T'n'C handle before use. See page 30.

Troubleshooting

Fault	Cause	Solution
Little suction power, machine stops	Filter bag overfilled?	Replace filter bag, see maintenance
	Suction pipe, suction hose or nozzle obstructed?	Remove dirt from suction pipe, suction hose or nozzle.
	Inlet filter coated?	Clean inlet filter, see maintenance
	Comfort: Exhaust filter obstructed? *	Clean exhaust filter, see maintenance
	Secondary air valve open at handle?	Close secondary air valve at handle
Machine stops unexpected	Motor shut off by thermal overload switch?	The suction motor is provided with a thermal overload switch. This shuts off the motor automatically if it overheats. After cooling off (may last up to 30 minutes), the motor starts up again.
Red LED lights up *	Filter bag overfilled?	Replace filter bag, see maintenance
	Saugrohr, Saugschlauch oder Düse verstopft?	Remove dirt from suction pipe, suction hose or nozzle.

Troubleshooting

Touch'n'Clean handle does not function **	Mains plug connected?	Connect mains plug.
	Handle coupled with the vacuum cleaner?	Disconnect mains plug, wait for 7 sec. Connect mains plug and touch handle 4 times.
	Touch'n'Clean handle battery empty?	See charge the Touch'n'Clean handle page 30.

If the problem persists, contact your Wetrok Service agent or authorized specialist.

Storage, disposal



If the machine is not to be used for a lengthy period, it must be dried out and stored under normal room conditions.

Disposal

- Packaging and cleaning agents must be disposed of according to national laws and provisions.
- Machine must be disposed of according to national laws and provisions.
- Observe recycling symbols on plastic parts!
- Spare parts list available on demand. Otherwise contact your Wetrok Service Agent for reordering.
- The battery installed in the T'n'C handle cannot be replaced. Dispose of the T'n'C handle according to the national laws and provisions.

Technical Data

Technical modifications reserved. For this reason, the machine may differ in details from the information in the operating instructions.

Type		Monovac Comfort 6 Touch'n'Clean	Monovac Comfort 11 Touch'n'Clean
Mains connection	V/Hz	220-240 V 50-60 Hz	220-240 V 50-60 Hz
Capacity	l	6	11
Livelli di potenza		2-level	2-level
Power	Watt	400/900	400/900
Vacuum	mbar	241	241
Air flow	l/s	45.7	45.7
Cable length	m	12	12
Total height	cm	38	38
Total length	cm	40	40
Total width	cm	32	32
Weight without accessories	kg	6.1	6.5

Monovac

Type		Monovac Comfort 6 Touch'n'Clean	Monovac Comfort 11 Touch'n'Clean
Sound power level	dB A EN 60335, ISO 4871	69 (ECO 65)	69 (ECO 65)
Sound power level precision	dB	2	2
Sound pressure level	dB EN 60335, ISO 4871	56 (ECO 52)	56 (ECO 52)
Sound pressure level precision	dB	2	2
Frequency radio control *	MHz	868	868
Vibration emission (IEC/EN 60335-2-72);	m/s ²	< 2.5	< 2.5

Type		Monovac Comfort 6 Touch'n'Clean	Monovac Comfort 11 Touch'n'Clean
Vibration emission precision	m/s ²	0.2	0.2
Ambiant temperature from/to		+ 5°C + 35°C	+ 5°C + 35°C
Battery type / tension T'n'C handle	Li-Po	3.7 V	3.7 V

* Touch'n'Clean

Technical Data

Type		Durovac 6	Durovac 11
Mains connection	V/Hz	220-240 V 50-60 Hz	220-240 V 50-60 Hz
Capacity	l	6	11
Power	Watt	900	900
Vacuum	mbar	241	241
Air flow	l/s	45.7	45.7
Cable length	m	10	10
Total height	cm	38	38
Total length	cm	40	40
Total width	cm	32	32
Weight without accessories	kg	6.1	6.5
Sound power level	dB A EN 60335, ISO 4871	70	70
Sound power level precision	dB	2	2
Sound pressure level precision	dB	2	2
Sound pressure level	dB EN 60335, ISO 4871	58	58

Type		Durovac 6	Durovac 11
Energy class		B	B
Vibration emission (IEC/EN 60335-2-72):	m/s ²	< 2.5	< 2.5
Vibration emission precision	m/s ²	0.2	0.2
Vibration emission (IEC/EN 60335-2-72):	m/s ²	< 2.5	< 2.5

Copyright

This set of operating instructions is our property as concerns copyright. It is only entrusted to buyers of this machine. All rights, particularly the right to reproduce or translate, belong to Wetrok AG. Violation obligates compensation for damages. We reserve all other statutory claims. The language of the original edition of these instructions is German.



Declaration of Conformity

in accordance with UK Government guidance



This declaration is issued under the sole responsibility of the manufacturer,

Wetrok AG, Steinackerstrasse 62, 8302 Kloten, Switzerland

Product	Vacuum cleaner
Type	Monovac 6/11
Model no.	40700 - 40740

The object of the declaration described above is in conformity with the relevant UK Statutory Instruments (and their amendments):

2016:1101	Electrical Equipment (Safety) Regulations 2016 (LVD)
2016:1101	Electromagnetic Compatibility Regulations 2016 (EMC)

and complies with the following technical standards

EN 60335-2-69:2012; EN 60335-1:2012 + A11:014; EN 55014-1:2006 + A1:2009 + A2:2011; EN 55014-2:1997 + A1:2001 + A2:2008, category 1; EN 61000-3-2:2014; EN 61000-3-3:2013

UK Authorised Representative (for authorities only):

Jigsaw Cleaning Systems Ltd
7 Ferry Road Office Park
Preston
PR2 2YH

Signed for and on behalf of Wetrok AG, Steinackerstrasse 62, 8302 Kloten, Switzerland
Kloten, 10.08.2022

Thomas Kyburz
CEO
Wetrok AG



Declaration of Conformity

in accordance with UK Government guidance



This declaration is issued under the sole responsibility of the manufacturer,

Wetrok AG, Steinackerstrasse 62, 8302 Kloten, Switzerland

Product	Vacuum cleaner
Type	Monovac 6/11 Touch'n'Clean
Model no.	40720 - 40750

The object of the declaration described above is in conformity with the relevant UK Statutory Instruments (and their amendments):

2016:1101	Electrical Equipment (Safety) Regulations 2016 (LVD)
2016:1101	Electromagnetic Compatibility Regulations 2016 (EMC)

and complies with the following technical standards

EN 60335-2-69:2012; EN 60335-1:2012 + A11:014; EN 55014-1:2006 + A1:2009 + A2:2011; EN 55014-2:1997 + A1:2001 + A2:2008, category 1; EN 61000-3-2:2014; EN 61000-3-3:2013
Touch'n'Clean: EN 60950-1:2006 + A11:2009 + A1:2010 + A12:2011 + A2:2013

UK Authorised Representative (for authorities only):

Jigsaw Cleaning Systems Ltd
7 Ferry Road Office Park
Preston
PR2 2YH

Signed for and on behalf of Wetrok AG, Steinackerstrasse 62, 8302 Kloten, Switzerland
Kloten, 10.08.2022

Thomas Kyburz
CEO
Wetrok AG



Declaration of Conformity

in accordance with UK Government guidance



This declaration is issued under the sole responsibility of the manufacturer,

Wetrok AG, Steinackerstrasse 62, 8302 Kloten, Switzerland

Product Vacuum cleaner
Type Durovac 6/11
Model no. 40700 - 40730

The object of the declaration described above is in conformity with the relevant UK Statutory Instruments (and their amendments):

2016:1101 Electrical Equipment (Safety) Regulations 2016 (LVD)
2016:1101 Electromagnetic Compatibility Regulations 2016 (EMC)

and complies with the following technical standards

EN 60335-2-69:2012; EN 60335-1:2012 + A11:014; EN 55014-1:2006 + A1:2009 + A2:2011; EN 55014-2:1997 + A1:2001 + A2:2008, category 1; EN 61000-3-2:2014; EN 61000-3-3:2013

UK Authorised Representative (for authorities only):

Jigsaw Cleaning Systems Ltd
7 Ferry Road Office Park
Preston
PR2 2YH

Signed for and on behalf of Wetrok AG, Steinackerstrasse 62, 8302 Kloten, Switzerland
Kloten, 10.08.2022

Thomas Kyburz
CEO
Wetrok AG

Wetrok AG Steinackerstrasse 62, CH-8302 Kloten
Tel +41 43 255 51 51, Fax +41 43 255 53 79

Wetrok Austria GmbH Deutschstrasse 19, A-1230 Wien
Tel 0800 20 48 68, Fax 0800 20 48 78

Wetrok GmbH Maybachstrasse 35, D-51381 Leverkusen
Tel +49 2171 398-0, Fax +49 2171 398-100

Wetrok Polska S.A. ul. Łączyny 4, PL-02-820 Warszawa
Tel +48 22 331 20 50, Fax +48 22 331 20 60

Wetrok AB Bergkällavägen 32, S-192 79 Sollentuna
Tel +46 8 444 34 00, Fax +46 8 444 34 01

www.wetrok.com

